



UC Santa Cruz
 Jack Baskin Building
 Santa Cruz, Ca. 95064

Project Phase Number
Phase 2 & 3

ISEC Project Number
115733

Specification Sections
 --- --- ---

ISEC General Notes

- All wall to wall dimensions must be field verified prior to release of tops for fabrication.
- FV - Indicates dimension to be field verified prior to release of materials for fabrication.
- * - Indicates minimum dimension required.
- ± - Indicates area of casework to be reduced or increased based on field verified dimensions.
- Twelve (12) digit product numbers indicates products are in Fisher Hamilton's nonstandard product line and require a thirteen (13) week minimum manufacturing time.
- All dimensions shown on plan view are for work surfaces only.
- Upper storage units &/or shelving are not shown on the rough-in plan for clarity.
- All dimensions shown on elevations are for casework and related accessory items only.
- Casework color and work surface color are to be selected prior to release of any materials for fabrication.
- Service fixture holes to have 1" diameter hole unless otherwise noted.
 - Water fixture holes to have 1-3/8" diameter holes unless otherwise noted.
 - Electrical Pedestal or Monuments to have 1-3/8" diameter holes unless otherwise noted.
 - All other hole sizes will be called out on Work Surface Plans as required.
- All casework dimensions are listed as: Width x Height x Depth.
- All Linear Foot material dimensions (i.e. shelving) are listed as: Length x Depth x Thickness.
- All sink bowl dimensions are listed as: Side to Side x Front to Back x Bowl Depth.
- Reference the Symbols & Abbreviations Section for additional information.

Project Specific Notes

- All tops to be Epoxy Resin unless otherwise noted on drawings.
- See Product Options Menu for Lock Types - Designated by Cabinet Suffix "L"
 - Key all locks alike, group by room, & provide master key. (MOST TYPICAL)
 - No Locks required for this project. (Note: All Solvent Storage Cabinets Are Lockable)
 - Key all locks different & provide master key.
 - Key all locks alike & provide master key.
 - Key all locks per Lock Schedule, see SCH.01
- Base molding to be supplied and installed by Others.
- Plug mold to be supplied by Others and installed by Others.
- Fixtures, sinks and outlets to be supplied by ISEC and installed by Others.
- Tailpieces and p-traps to be supplied by Others and installed by Others.
- Stainless Steel Drop-In sink cutouts to be made 3/4" less in Front to Back & Side to Side than the overall size of sink. Corners of cutout may be square or any radius up to 1/2".
- Epoxy Resin Drop-In sink cutouts to be made 1-1/8" more than the Side to Side & Front to Back than the I.D. of the sink bowl. Sink cutouts to have 1-1/2" radius at all corners unless noted otherwise.

Project Location Map

Project Vicinity Map

Space Reserved for Approval Stamp

Symbols

Plan Symbols:

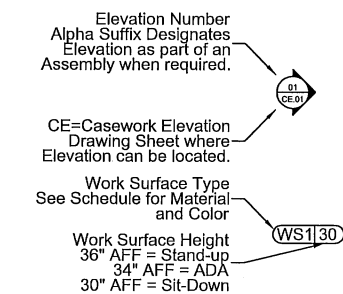

Elevation Symbols:

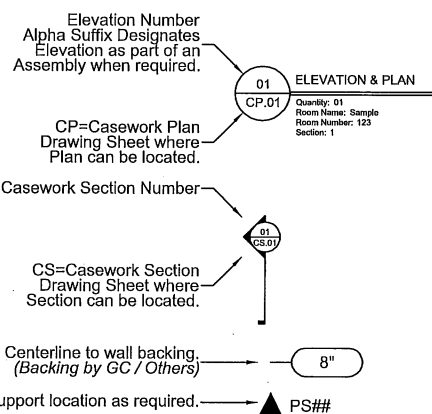

Abbreviations

- General:**
- ADA American Disabilities Act
 - ADJ Adjustable
 - AFF Above Finished Floor
 - CO Cut-Out
 - (E) Existing
 - EOPM Equipment
 - GA Gauge
 - LH Left Hand
 - OH Opposite Hand
 - QC Quality Control
 - REF Reference
 - RH Right Hand
 - SIM Similar
 - UC Under Counter
 - UNO Unless Noted Otherwise
- Products:**
- FH Fume Hood
 - CAV Constant Air Volume
 - VAV Variable Air Volume
 - KO or KS Knee Space Opening
 - PB Peg Board
 - SK Sink
 - CS Cup Sink
 - WKSF Work Surface
 - FTD Paper Towel Dispenser
 - SD Soap Dispenser
- Materials:**
- ER Epoxy Resin
 - PL Plastic Laminate
 - SS Stainless Steel
 - SP Solid Phenolic
 - WD Wood
 - HDWD Hardwood
 - PLY Plywood
 - PVC Polyvinyl Chloride
- Service Fixtures:**
- CW Cold Water
 - HW Hot Water
 - H/CW Hot & Cold Water Mixing
 - DI Distilled Water
 - DW Deionized Water
 - EW Eyewash
 - E or ELEC Electrical
 - CA Compressed Air
 - N Natural Gas
 - V Vacuum
 - NIT Nitrogen
 - OXY Oxygen
 - CDA Compressed Dry Air
- Dimensioning:**
- C Centerline
 - CONT Continuous
 - CU Cubic Foot
 - DIA Diameter
 - EQ Equally Spaced
 - FV Field Verify
 - ID Inside Diameter
 - LF Linear Foot
 - MIN Minimum
 - MAX Maximum
 - NTS Not To Scale
 - OC On-Center
 - OD Outside Diameter
 - SF Square Foot
 - CIF Cut In Field
 - CO Cutout
- Equipment:**
- NIC Not In Contract
 - OFOI Owner Furnish Owner Install
 - OFCI Owner Furnish Contractor Install
 - CFOI Contractor Furnish Owner Install
- Model Numbers:**
- 148S6320.2,3
 - Section (Used for Shipping)
 - Grouping (Not Used)
 - Quantity Override
 - Hamilton Model Number

Project Vendors / Memberships



Architect

GL Partners
 San Francisco, Ca.

e-mail: ---
 Phone: ---
 Fax: ---

General Contractor

e-mail: ---
 Phone: ---
 Fax: ---

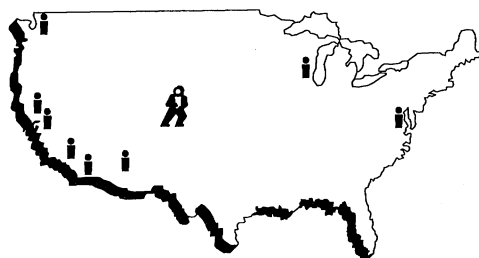

ISEC Corporate Office

33 Inverness Drive East
 Englewood, CO 80112
 Phone: (303) 790-1444
 Fax: (303) 790-7104
 www.isecinc.com

Northern California Region

41734 Christy Street
 Fremont, CA 94538
 Phone: (510) 490-1333
 Fax: (510) 656-8764
 Contact: Debbie Silva

Drawing Set Date

Drawing Set Revisions

No.	Date	By	Description
0	10/05/07	---	DESIGN SET
1	10/16/07	JF	Updated Design Drawings
2	10/23/07	JF	CASEWORK CHANGE
3	---	---	---
4	---	---	---
5	---	---	---
6	---	---	---
7	---	---	---
8	---	---	---
9	---	---	---

Notice

Documents and drawings remain the property of ISEC, Inc. and are protected by copyright and shall not be reproduced, copied, indirectly described, submitted to or reviewed by other parties without written authorization by ISEC, Inc. Violations will result in prosecution under U.S. Copyright Laws.

Denver • Los Angeles • Milwaukee • Phoenix • San Diego • San Francisco • Sacramento • Seattle • Washington DC

Project Drawing Schedule

Sheet Number	Sheet Title	Rev. #	Revision Date
--	Cover	0	--
Option and Schedule Sheets			
SCH.01	Drawing Schedule	0	--
SCH.02	Sinks - Fixtures - Worksurfaces Schedules	0	--
SCH.03	Product and Color Options - Steel	0	--
Floor Plan Sheets			
CP.01	Floor Plan for Over-All Area	0	--
CP.02	Floor Plan for Area 206 & 207 & 208	0	--
Elevation Sheets			
CE.01	Elevation(s) 01 for Room 206	0	--
CE.02	Elevation(s) 02A & 02B for Room 206	0	--
CE.03	Elevation(s) 02C for Room 206	0	--
CE.04	Elevation(s) 03A & 03B for Room 206	0	--
CE.05	Elevation(s) 03C for Room 206	0	--
CE.06	Elevation(s) 04 for Room 206	0	--
CE.07	Elevation(s) 05 for Room 206	0	--
CE.08	Elevation(s) 06A & 06B for Room 208	0	--
CE.09	Elevation(s) 07 for Room 208	0	--
CE.10	Elevation(s) 08 for Room 207	0	--
Detail Sheets			
CD.01	Details for Acrylic Splash	0	--



Isec Corporate Office
 33 Inverness Drive East
 Englewood, CO 80112
 Phone: (303) 790-1444
 Fax: (303) 790-7104
 www.isecinc.com

Northern California Region
 41734 Christy Street
 Fremont, CA 94538
 Phone: (510) 490-1333
 Fax: (510) 656-8764
 Contact: Debbie Silva

Project Name
UC Santa Cruz

Project Location
Santa Cruz, Ca. 95064

Project Number	Drawing Schedule				
115733					
Project Phase Number	Drawn By	QC By	Last Revised By	Drawing Set Date	Drawing Number
Phase 2 & 3	----	----	----	----	SCH.01
	10/05/07		0		

Worksurface and Shelving Schedules

Epoxy Resin Worksurfaces:							
Type	Color	Thickness	Depth	Front Edge	Front Edge Detail	Backsplash	Backsplash Detail
WS01	Black	1"	See Elev.	1/8" Bevel	-	4" High Field Applied Loose Splash, Unless Otherwise Noted	-
Plastic Laminate Worksurfaces:							
Type	Color	Core Material Laminate Backing	Depth	Front Edge	Front Edge Detail	Backsplash	Backsplash Detail
Plastic Laminate Shelves:							
Type	Color	Core Material Laminate Backing	Depth	Front Edge	Front Edge Detail	Back & Side Edges	Back & Side Edge Details

Note: Please contact your ISEC representative to request actual color samples prior to making your final color selections.

Service Fixture Schedule

Water Fixtures:							
Arch. Ref.	ISEC Ref.	Manufacturer	Service	Type	Description	Finish	Model #
-	F01	WaterSaver	ICW/IHW	Deck Mounted	Mixing Faucet w/6" Swing Gooseneck	Forged Brass Body with Chrome Plated Finish	L692-10
-	DI01	WaterSaver	Distilled / Deionized	Deck Mounted	Water Fixture	Forged Brass Body with Chrome Plated Finish	L412-10-55
Service Fixtures:							
-	SF01-AIR	QDP	AIR	Deck Mounted	Service Fixture	Forged Brass Body with Chrome Plated Finish	L2880-131WSA
-	SF01-VAC	QDP	VAC	Deck Mounted	Service Fixture	Forged Brass Body with Chrome Plated Finish	L2880-131WSA
-	SF01-GAS	QDP	GAS	Deck Mounted	Service Fixture	Forged Brass Body with Chrome Plated Finish	L2880-131WSA
-	SF03-AIR	QDP	AIR	Deck Mounted	Service Fixture	Forged Brass Body with Chrome Plated Finish	L2880-132SWSA
-	SF03-VAC	QDP	VAC	Deck Mounted	Service Fixture	Forged Brass Body with Chrome Plated Finish	L2880-132SWSA
-	SF03-GAS	QDP	GAS	Deck Mounted	Service Fixture	Forged Brass Body with Chrome Plated Finish	L2880-132SWSA
Emergency Fixtures:							

Sink Schedule

Sinks:								
Arch. Ref.	ISEC Ref.	Manufacturer	Color / Finish	Type	Sink ID Size	Outlet	Accessories	Model #
-	SK01	LabTops	Black Epoxy	Drop-In	25" x 15" x 10"	Corner	T05	D55
Cupsinks:								
-	CS04	QDP	Black Epoxy	Drop-In	3" x 6" x 4"	Center	-	34L13200

Miscellaneous Equipment Schedule

Arch. Ref.	ISEC Ref.	Manufacturer	Description	Model #
-	AS01	-	Acrylic Splash w/ Peg Board	-

Steel Casework Colors

Color Option Category Name	Color	Color Code
Base Color		
Accent (Steel)		



ISEC Corporate Office
 33 Inverness Drive East
 Englewood, CO 80112
 Phone: (303) 790-1444
 Fax: (303) 790-7104
 www.isecinc.com

Northern California Region
 41734 Christy Street
 Fremont, CA 94538
 Phone: (510) 490-1333
 Fax: (510) 656-8764
 Contact: Debbie Silva

Project Name
UC Santa Cruz

Project Location
Santa Cruz, Ca. 95064

Project Number 115733	Drawing Title Sinks - Fixtures - Worksurfaces Schedules			
Project Phase Number Phase 2 & 3	Drawn By 10/05/07	QC By ----	Last Revised By ----	Drawing Set Date ----
				Drawing Number SCH.02

Wood Product Options

Short Menu

← Check for ALL Standard Default selections.

- 1. **Cabinet Front and/or Drawer Style**
 - Regency flush overlay – **Standard Default**
 - Legacy lipped overlay
 - Profile radius overlay
 - Plastic laminate flush overlay
- 2. **Veneer Type**
 - Plain-sliced Red Oak – **Standard Default**
 - Rift-cut Red Oak
 - Plain-sliced select White Maple
 - Rotary-sliced select White Maple
- 3. **Grain Direction**
 - Combination – **Standard Default**
 - Vertical-matched (flush overlay Regency only)
- 4. **Cabinet Core (sides and bottom)**
 - Veneer core plywood – **Standard Default**
 - Particleboard core plywood
- 5. **3mm Edgeband Color for Plastic Laminate Face**
(wood edgeband on wood face)
 - Black
 - Gray
 - Chameleon
 - White
- 6. **Cabinet Top Frame**
 - Front horizontal and rear vertical rails – **Standard Default**
 - Full top frame
- 7. **Intermediate Front Rails**
 - Without – **Standard Default** for Regency flush & Profile radius overlay
 - With – **Standard Default** for Legacy lipped overlay
- 8. **Intermediate Rear Rails**
 - Without – **Standard Default**
 - With
- 9. **Security Panels (only on locked cabinets)**
 - Without – **Standard Default** (21.5" deep base cabinets)
 - With security panels including front/rear rails – **Standard Default**
(15" deep base cabinets with locks)
- 10. **Removable Back Panel (base cabinet only)**
 - One-piece behind cupboard and 36" to 48" wide drawer units. Open behind drawers on less than 36" wide units – **Standard Default**
 - Two-piece behind drawers, one-piece behind cupboard
- 10a. **Fixed Backs (tall, wall & upper case only – solid doors only)**
 - Veneer MDF core plywood – **Standard Default**
 - Tempered hardboard

- 11. **Drawer Construction, Drawer Height**
 - Standard height – **Standard Default**
 - Extended height
- 12. **Drawer Construction, Drawer Joinery**
 - Lockjoint, 5mm white finished MDF, no divider grooves – **Standard Default**
 - Lockjoint, 5mm white finished MDF, with divider grooves
 - Lockjoint, 5mm temporary bottom, no divider grooves
 - Lockjoint, 5mm temporary bottom, with divider grooves
 - Multiple dovetail, 5mm white PVC clad MDF, no divider grooves
 - Multiple dovetail, 5mm white PVC clad MDF, with divider grooves
- 13. **Drawer Suspension**
All file drawers have 150-pound Overtravel slides as standard
 - 3/4 Extension, open roller, 100-pound dynamic self-closing, epoxy-coated – **Standard Default**
 - Overtravel, ball-bearing, 150-pound dynamic, zinc-plated – **Standard Default on all File Drawers** (not available on 15" deep cabinets)*

*Not available on drawers with heads 4-mod high or less – if this option is selected, drawers with heads 4-mod high or less will be furnished with 100-pound full-extension slide

 - Full-extension 100-pound zinc-plated
 - Full-extension 100-pound epoxy-coated
 - Full-extension self-closing zinc-plated
 - Full-extension self-closing epoxy-coated
- 14. **Shelf Material**
 - Wood – **Standard Default**
 - Steel (color = Cognac)

Adjustable shelves only; veneer core plywood on fixed shelves
- 15. **Base Cabinet Shelf Depth**
 - Half depth, 12" shelf – **Standard Default**
 - Full depth, 17.75" shelf
 - Split depth, two 8.875" shelves
- 16. **Shelf Thickness (wood only – steel is 3/4" thick)**
 - All shelves, 1" thick – 100-pound rating – **Standard Default**
- 17. **Shelf Clips**
 - Plated pin & socket – **Standard Default**
 - Plastic twin-pin (seismic)

Fisher Hamilton L.L.C. ▪ 1316 18th Street, Two Rivers, WI 54241 USA ▪ Phone: 920.793.1121 ▪ Fax: 920.793.3084 ▪ www.fisherhamilton.com
AL-1323-18 October 2006

Wood Product Options – Page 2

Short Menu

- 18. **Drawer/Door Pull Direction**
 - Configuration 1 – **Standard Default**
Horizontal on drawers, vertical on doors
 - Configuration 2*
Horizontal on drawers and base unit doors
 - Configuration 3
Full width, horizontal on drawers, vertical on doors

* Note: Wall, upper and tall cases always have vertical pulls
- 19. **Pull Types**
Available in Configurations 1 and 2 only
 - Black wire (powder coat) – **Standard Default**
 - Goldtone wire (powder coat)
 - Stainless steel wire
 - Satin chrome wire
 - Polished chrome wire (plated)
 - Brite chrome wire (chrome powder coat)
 - Dove gray wire
 - Chameleon wire
 - Aluminum wire
 - Brushed aluminum rectangular
 - Semi-recessed polypropylene (Regency flush overlay, Profile radius and laminate flush overlay only)
 - Black
 - Chameleon
 - Gray
 - White
 - Flush aluminum (Regency flush overlay, Profile radius and laminate flush overlay only)
- 19a. **Pull Types**
Available in Configuration 3 only
 - Flush full-width aluminum (Regency flush overlay and laminate flush overlay only)
 - Flush full-width solid hardwood integral pull (Regency flush and Profile radius flush overlay only)
 - Flush full-width black PVC (Regency flush overlay only)
- 20. **Door Hinges**
 - 5-Knuckle
 - Black, steel – **Standard Default**
 - Goldtone, steel
 - Stainless steel
 - Dull chrome, plated
 - Satin chrome (Regency flush overlay only)
 - Dove gray, steel*
 - Chameleon, steel*
 - Brite chrome powder coat*
 - Concealed, self-closing, 155-degree*
 - 3-Barrel Hinge* (no catch required)

* Note: Regency flush overlay, profile radius and laminate flush only overlay
- 21. **Base – Plywood (Base Units Only)**
 - Integral with end panels – **Standard Default**
 - Integral with end panels with levelers
 - Separate, factory attached
 - Separate, field furnished/fabricated
- 21a. **Toekick (Tall Cases Only)**
 - Flush – **Standard Default**
 - Recessed

- 22. **Lock Types**
Designated by cabinet suffix "L."
 - Master 5-Disc – **Standard Default**
Use when up to 225 key changes are required.
 - Master 5-Pin*
 - Grand Master 5-Pin*
*Use when up to 2,000 primary key changes are required (Master and Grand Master).
Note: 5-pin option has an eight-week lead time. (Lock keying is determined by lock schedule.)
- 23. **Catches**
 - Roller – **Standard Default**
 - Magnetic
 - None (concealed and 3-barrel hinge)
- 24. **Label Holders**
 - None – **Standard Default**
 - One per door, one per drawer head
 - Black
 - Goldtone
 - Stainless Steel

Note: Check "None" when full width and semi-recessed Polypropylene pulls are selected.
- 25. **Glass**
 - Float glass – 3mm on wall, upper and tall cases; 6mm on wall and upper case solid sliding glass – **Standard Default**
 - Safety Glass – laminated 6mm on all units
 - Safety glass – tempered 3mm on wall, upper and tall cases; 6mm on wall and upper case solid sliding glass
- 26. **Finish**
 - Standard SEFA 8 – **Standard Default**
 - Standard SEFA 8 with concealed areas finished
 - U of WA
 - U of WA with concealed areas finished
- 27. **Suspension Hardware**
 - C-Frame – **Standard Default**
 - MAX

Fisher Hamilton L.L.C. ▪ 1316 18th Street, Two Rivers, WI 54241 USA ▪ Phone: 920.793.1121 ▪ Fax: 920.793.3084 ▪ www.fisherhamilton.com
AL-1323-18 October 2006



ISEC Corporate Office
33 Inverness Drive East
Englewood, CO 80112
Phone: (303) 790-1444
Fax: (303) 790-7104
www.isecinc.com

Northern California Region
41734 Christy Street
Fremont, CA 94538
Phone: (510) 490-1333
Fax: (510) 656-8764
Contact: Debbie Silva

Project Name
UC Santa Cruz
Project Location
Santa Cruz, Ca. 95064

Project Number 115733	Drawing Title Product And Color Options - Steel			
Project Phase Number Phase 2 & 3	Drawn By ----	QC By ----	Last Revised By ----	Drawing Set Date ----
	10/05/07			
			0	
				Drawing Number SCH.03

Fisher Hamilton Steel Casework Schedule

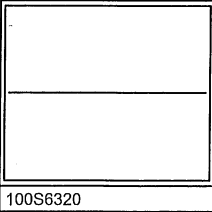
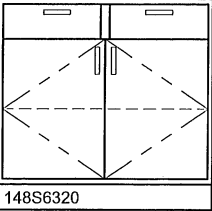
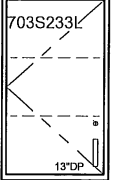
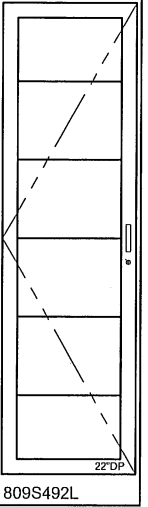
Base Cabinets:							
 100S6320							
Architect's Reference #							
 148S6320							
Architect's Reference #							
Wall Cabinets:							
 703S233L							
Architect's Reference #							
Tall Cabinets:							
 809S492L							
Architect's Reference #							



Isec Corporate Office
 33 Inverness Drive East
 Englewood, CO 80112
 Phone: (303) 790-1444
 Fax: (303) 790-7104
 www.isecinc.com

Northern California Region
 41734 Christy Street
 Fremont, CA 94538
 Phone: (510) 490-1333
 Fax: (510) 656-8764
 Contact: Debbie Silva

Project Name
UC Santa Cruz
Project Location
Santa Cruz, Ca. 95064

Project Number 115733	Drawing Title Casework Schedule - Steel				
Project Phase Number Phase 2 & 3	Drawn By ----	QC By ----	Last Revised By ----		Drawing Set Date ----
	10/05/07				Drawing Number SCH.04

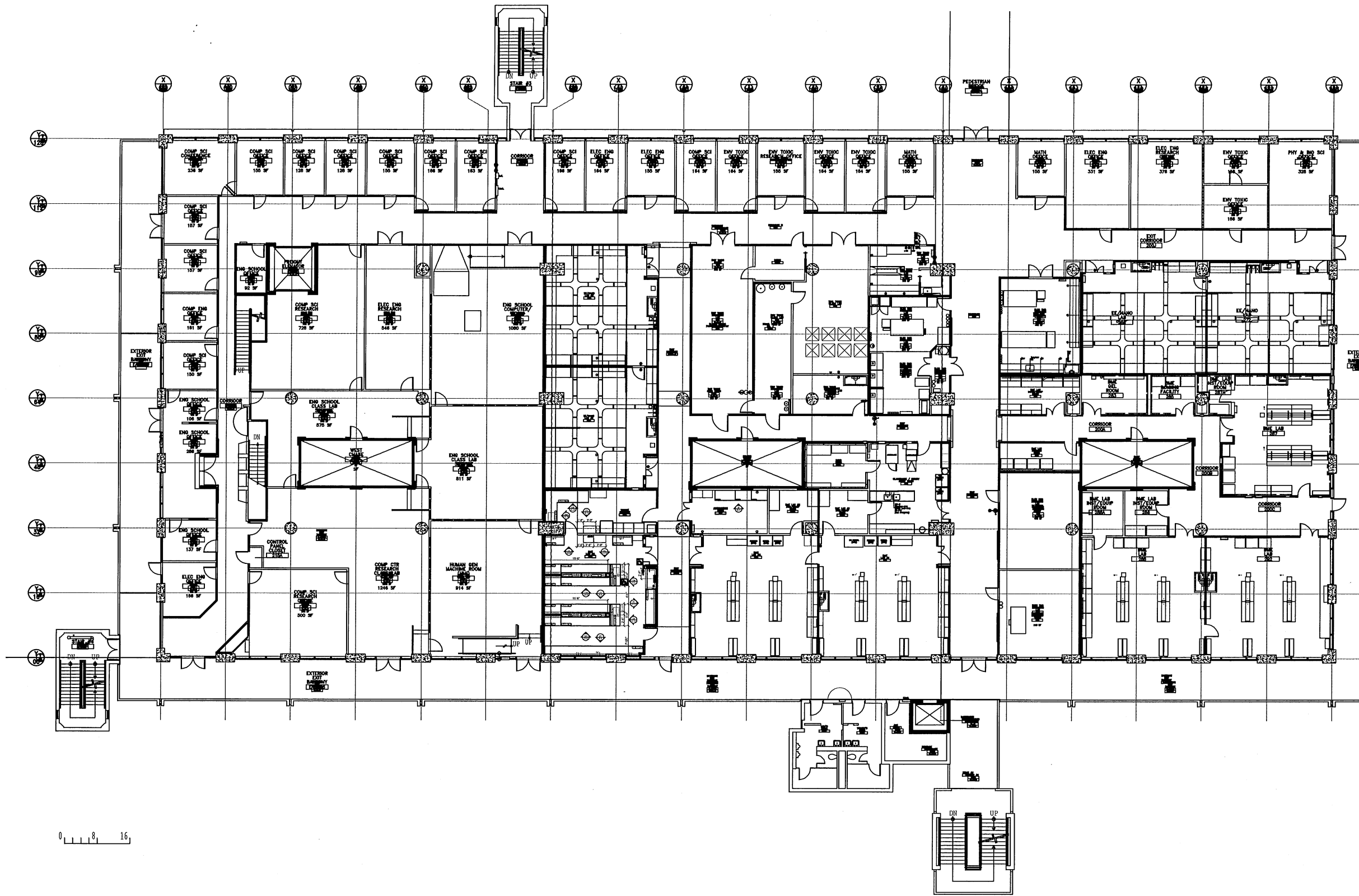

- ### ISEC Rough-in Notes
1. Indicates free area within each item, rough-ins must be located in this area.
 2. Indicates rough-in location above ceiling line.
 3. Rough-ins for items NOT BY ISEC are not shown on these drawings.
 4. Plumbing, electrical, and HVAC contractors are to coordinate specifications, Architect's mechanical drawings, and ISEC drawings for services required for each item.
 5. Rough-in drawings are advisory in nature, and are to be used as a guide by the Mechanical Contractors to effect rough-ins that will be within such portions of cabinet area to allow for access to shutoffs, traps, service lines and electric junction boxes.
 6. Variations from the rough-ins shown made necessary by beams or other building conditions shall in no way be considered a liability resulting from the preparation and submission of these drawings.
 7. Centerline shown for sinks is to the center of the sink base cabinet.
 8. Centerline shown for cupsinks on plans, is to the centerline of the outlet itself. Take note that the stub out needs to be offset to allow for the p-trap to connect to the tailpiece.

FLOOR PLAN FOR:
 1st Floor
 Reference Architectural Plan Sheet: AL-200



ISEC Corporate Office
 33 Inverness Drive East
 Englewood, CO 80112
 Phone: (303) 790-1444
 Fax: (303) 790-7104
 www.isecinc.com

Northern California Region
 41734 Christy Street
 Fremont, CA 94538
 Phone: (510) 490-1333
 Fax: (510) 656-8764
 Contact: Debbie Silva

Project Name
UC Santa Cruz
Project Location
Santa Cruz, Ca. 95064

Project Number 115733		Drawing Title Floor Plan For Over-All Area			
Project Phase Number Phase 2 & 3	Drawn By 10/05/07	QC By ---	Last Revised By ---	Drawing Set Date ---	Drawing Number CP.01

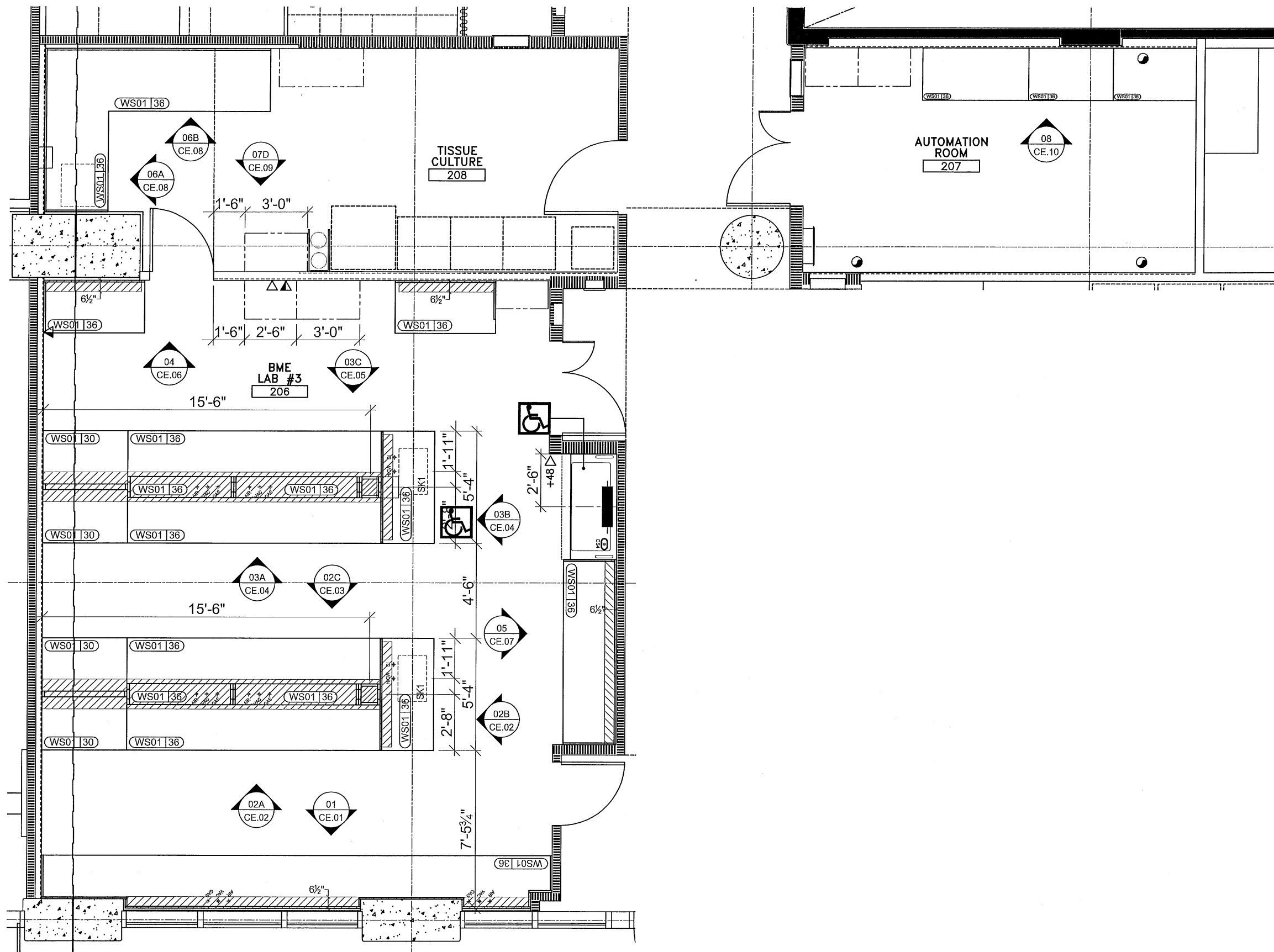

- ### ISEC Rough-in Notes
1. Indicates free area within each item, rough-ins must be located in this area.
 2. Indicates rough-in location above ceiling line.
 3. Rough-ins for items NOT BY ISEC are not shown on these drawings.
 4. Plumbing, electrical, and HVAC contractors are to coordinate specifications, Architect's mechanical drawings, and ISEC drawings for services required for each item.
 5. Rough-in drawings are advisory in nature, and are to be used as a guide by the Mechanical Contractors to effect rough-ins that will be within such portions of cabinet area to allow for access to shutoffs, traps, service lines and electric junction boxes.
 6. Variations from the rough-ins shown made necessary by beams or other building conditions shall in no way be considered a liability resulting from the preparation and submission of these drawings.
 7. Centerline shown for sinks is to the center of the sink base cabinet.
 8. Centerline shown for cupsinks on plans, is to the centerline of the outlet itself. Take note that the stub out needs to be offset to allow for the p-trap to connect to the tailpiece.

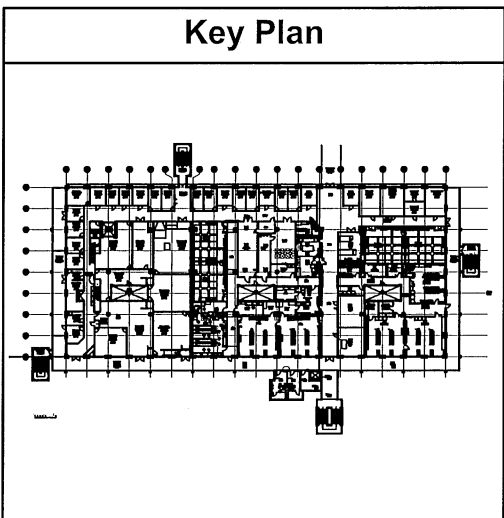

PARTIAL FLOOR PLAN FOR:
1st Floor
Reference Architectural Plan Sheet: _____

Isec *Integrity and Innovation. Right down to the finish.*

ISEC Corporate Office
33 Inverness Drive East
Englewood, CO 80112
Phone: (303) 790-1444
Fax: (303) 790-7104
www.Isecinc.com

Northern California Region
41734 Christy Street
Fremont, CA 94538
Phone: (510) 490-1333
Fax: (510) 656-8764
Contact: Debbie Silva

Project Name
UC Santa Cruz

Project Location
Santa Cruz, Ca. 95064

Project Number 115733	Drawing Title Floor Plan For Area 206 & 207 & 208				
Project Phase Number Phase 2 & 3	Drawn By ----	QC By ----	Last Revised By ----	Drawing Set Date ----	Drawing Number CP.02

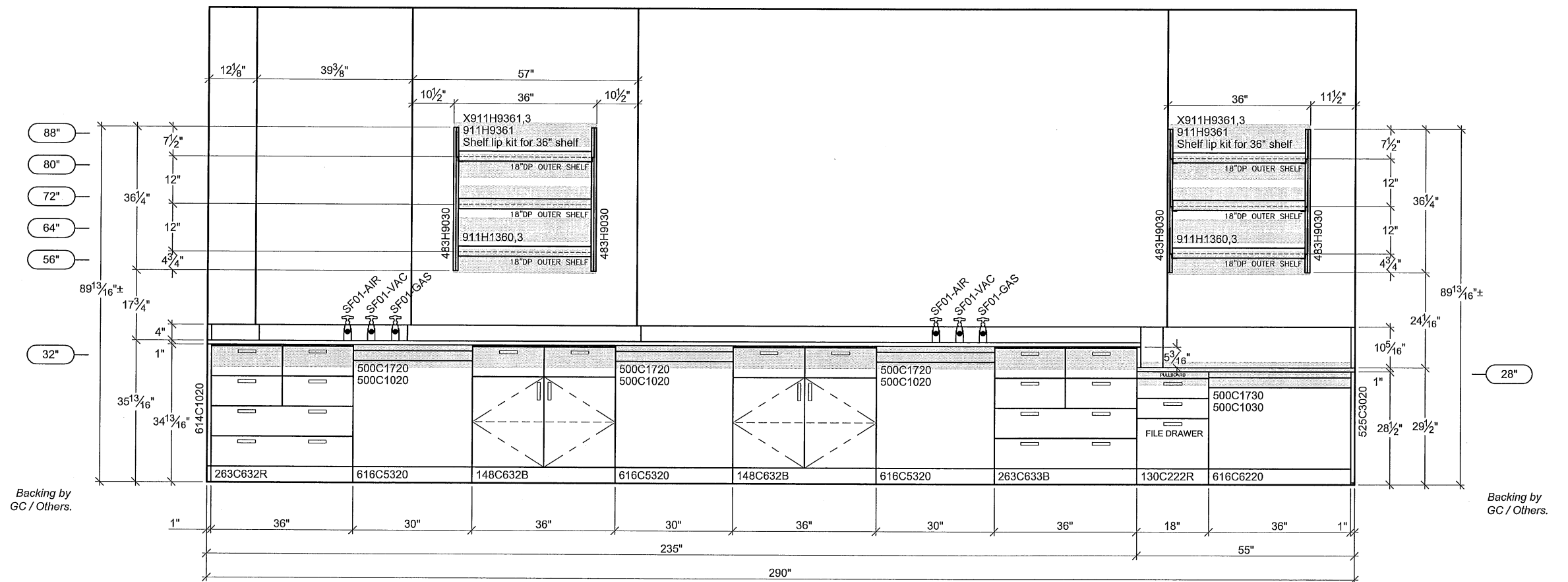
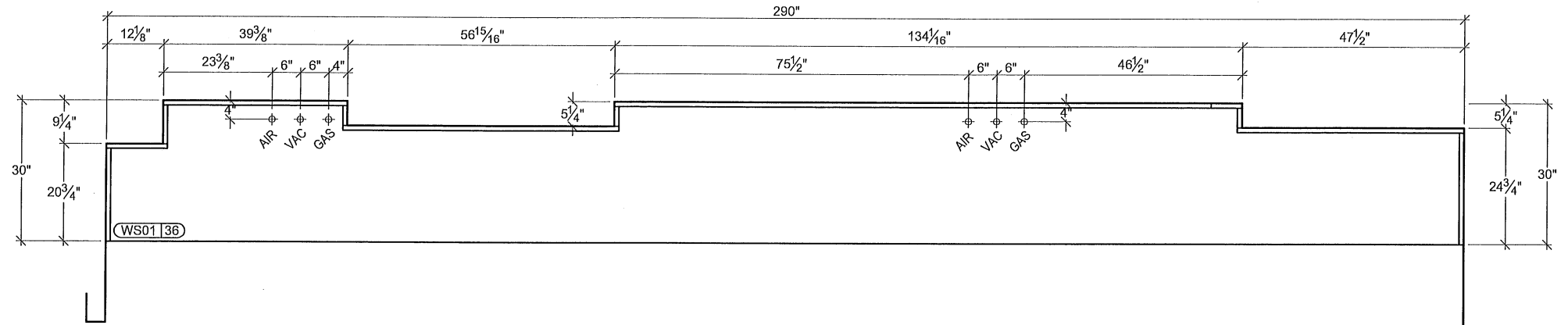

01 ELEVATION & PLAN
 CP.02 Quantity: 01
 Room Name: BME LAB#3
 Room Number: 206
 Section: S1
 Ref. Arch. Elev.:

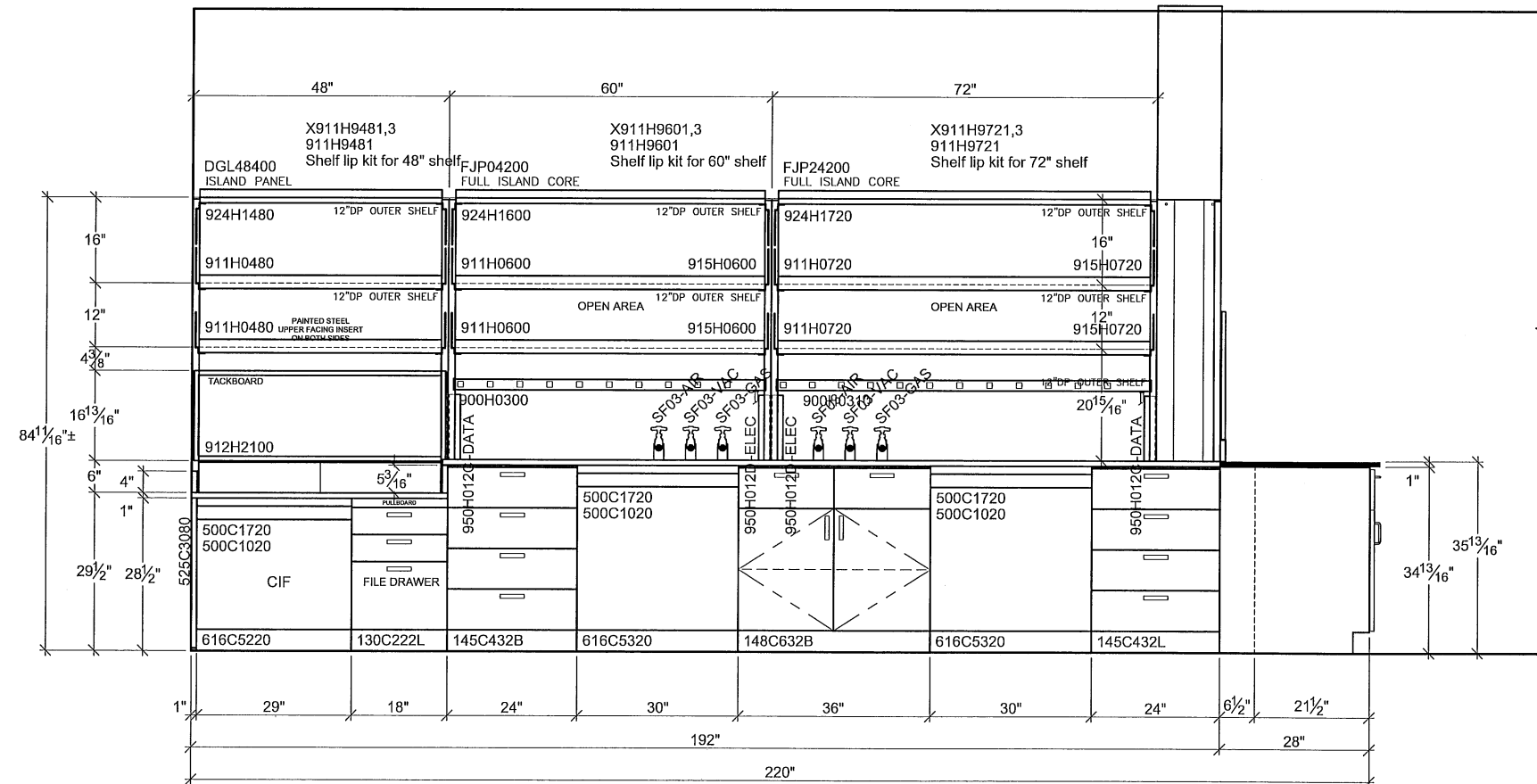
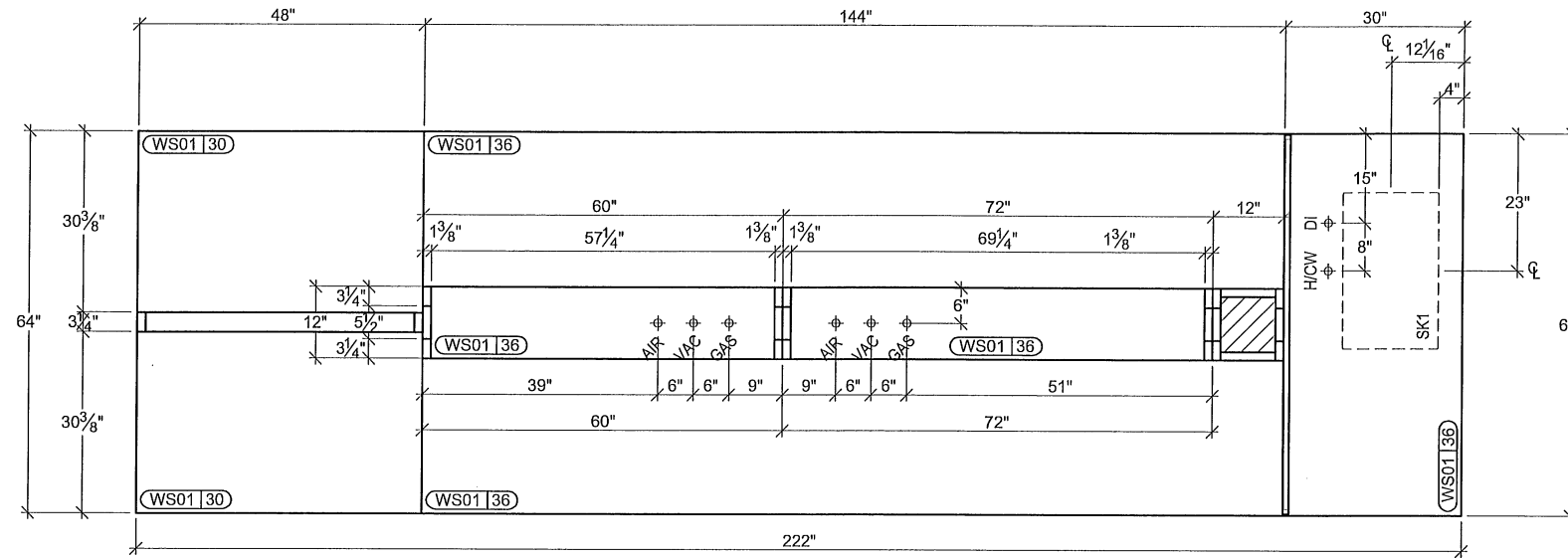

02A ELEVATION & PLAN
 CP.02 Quantity: 01
 Room Name: BME LAB#3
 Room Number: 206
 Section: S1
 Ref. Arch. Elev.:

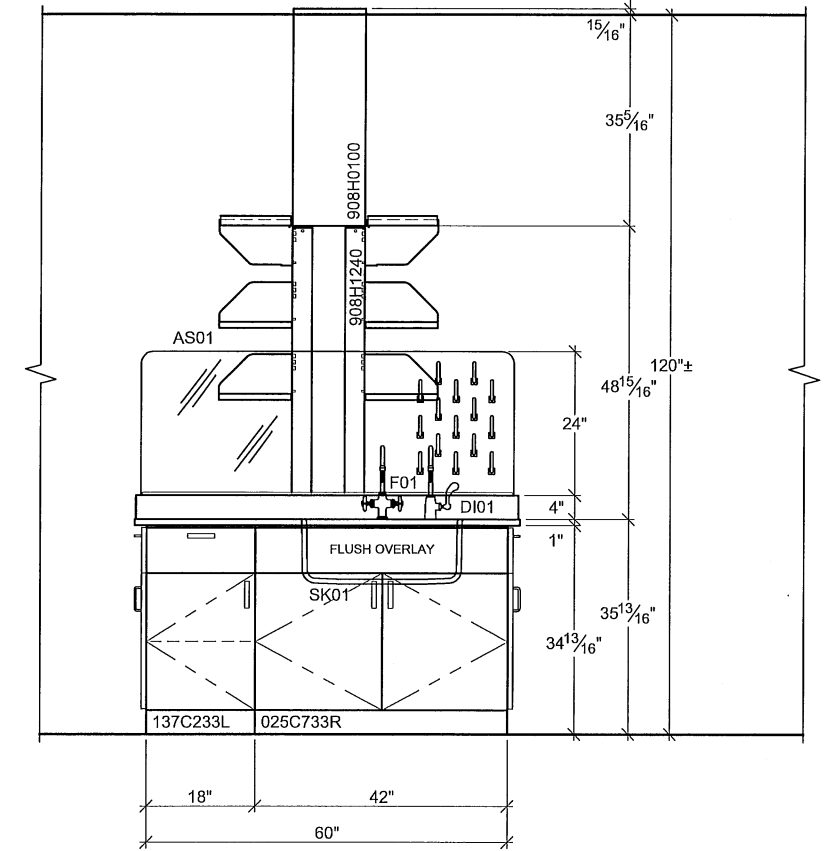

02B ELEVATION & PLAN
 CP.02 Quantity: 01
 Room Name: BME LAB#3
 Room Number: 206
 Section: S1
 Ref. Arch. Elev.:



ISEC Corporate Office
 33 Inverness Drive East
 Englewood, CO 80112
 Phone: (303) 790-1444
 Fax: (303) 790-7104
 www.isecinc.com

Northern California Region
 41734 Chrissy Street
 Fremont, CA 94538
 Phone: (510) 490-1333
 Fax: (510) 656-8764
 Contact: Debbie Silva

Project Name
UC Santa Cruz
 Project Location
Santa Cruz, Ca. 95064

Project Number 115733	Drawing Title Elevation(s) 02A & 02B For Room 206			
Project Phase Number Phase 2 & 3	Drawn By ----	QC By ----	Last Revised By ----	Drawing Set Date ----
			0	Drawing Number CE.02

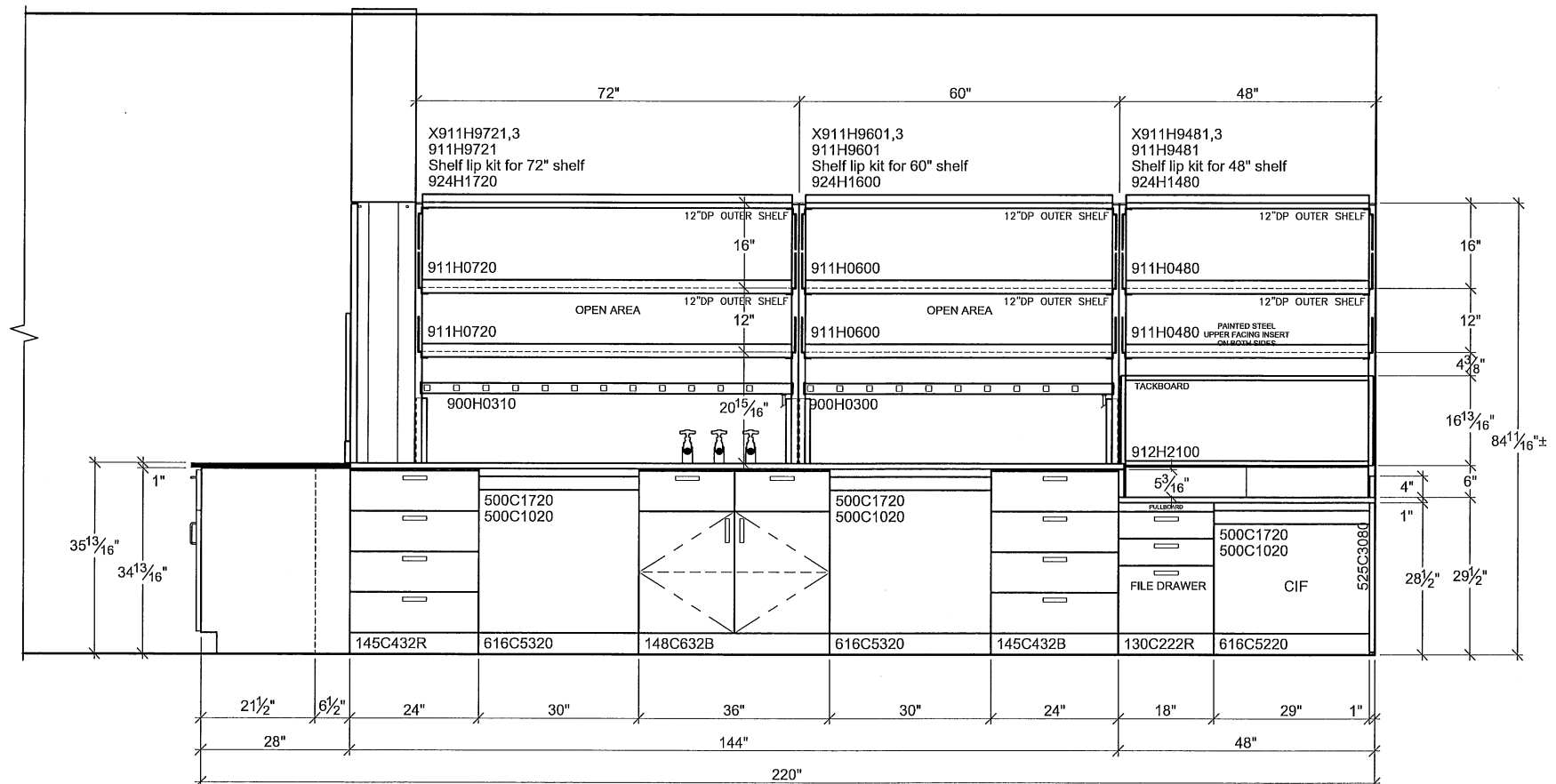

02C ELEVATION & PLAN

CP.02 Quantity: 01
 Room Name: BME LAB#3
 Room Number: 206
 Section: S1
 Ref. Arch. Elev.:



Isec Corporate Office
 33 Inverness Drive East
 Englewood, CO 80112
 Phone: (303) 790-1444
 Fax: (303) 790-7104
 www.isecinc.com

Northern California Region
 41734 Christy Street
 Fremont, CA 94538
 Phone: (510) 490-1333
 Fax: (510) 656-8764
 Contact: Debbie Silva

Project Name
UC Santa Cruz
 Project Location
Santa Cruz, Ca. 95064

Project Number 115733	Drawing Title Elevation(s) 02C For Room 206				
Project Phase Number Phase 2 & 3	Drawn By ----	QC By ----	Last Revised By ----	Drawing Set Date ----	Drawing Number CE.03

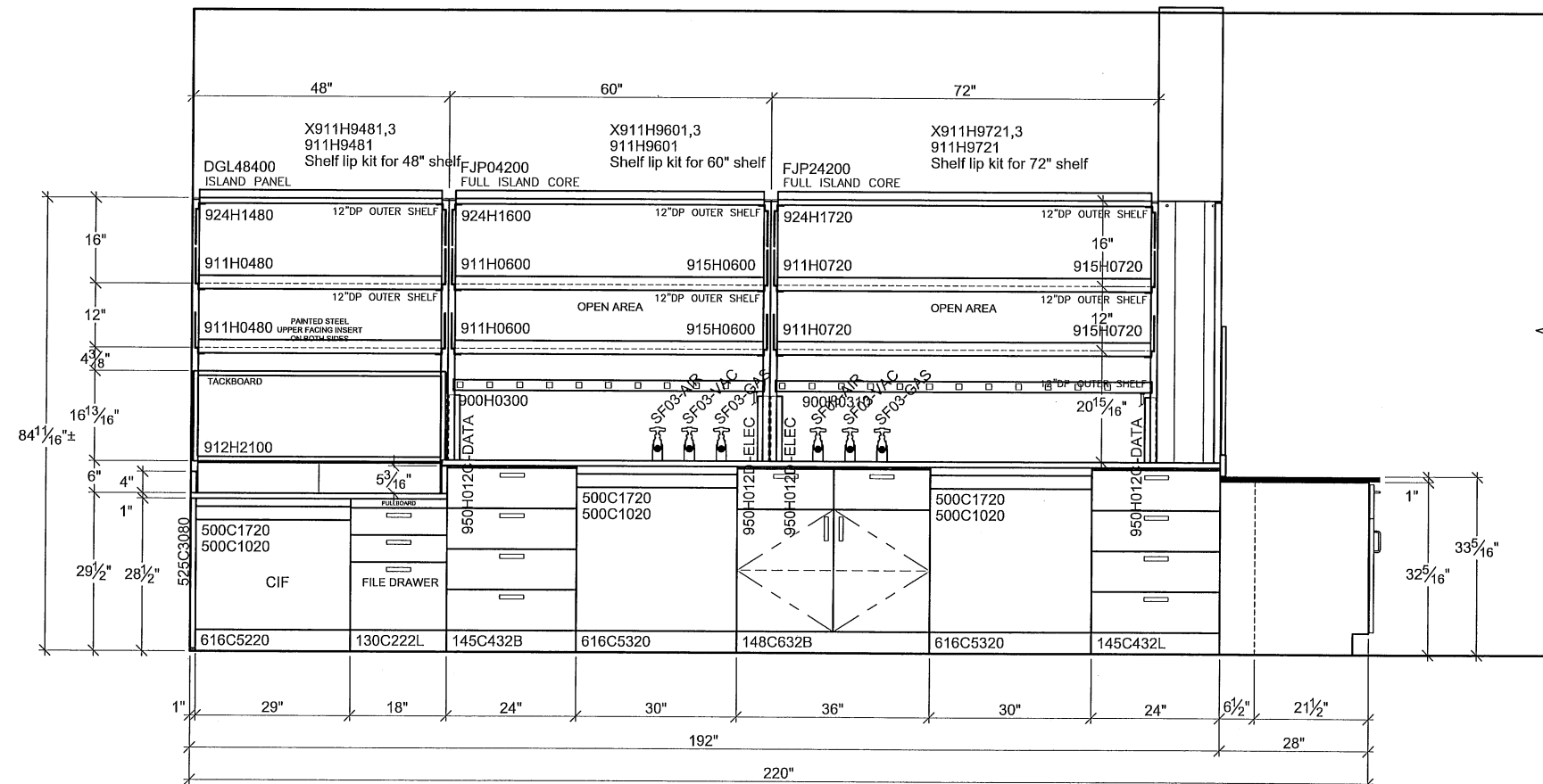
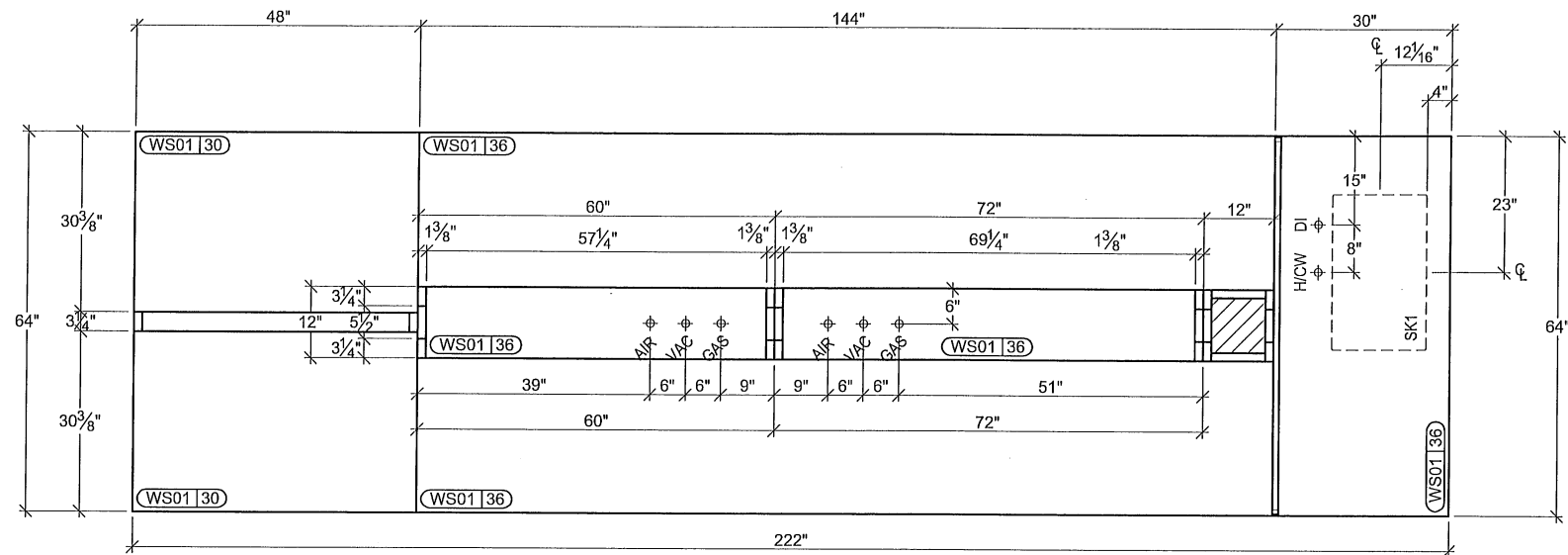

02A ELEVATION & PLAN

CP.01 Quantity: 01
 Room Name: LAB 206
 Room Number: 206
 Section: S1
 Ref. Arch. Elev.:

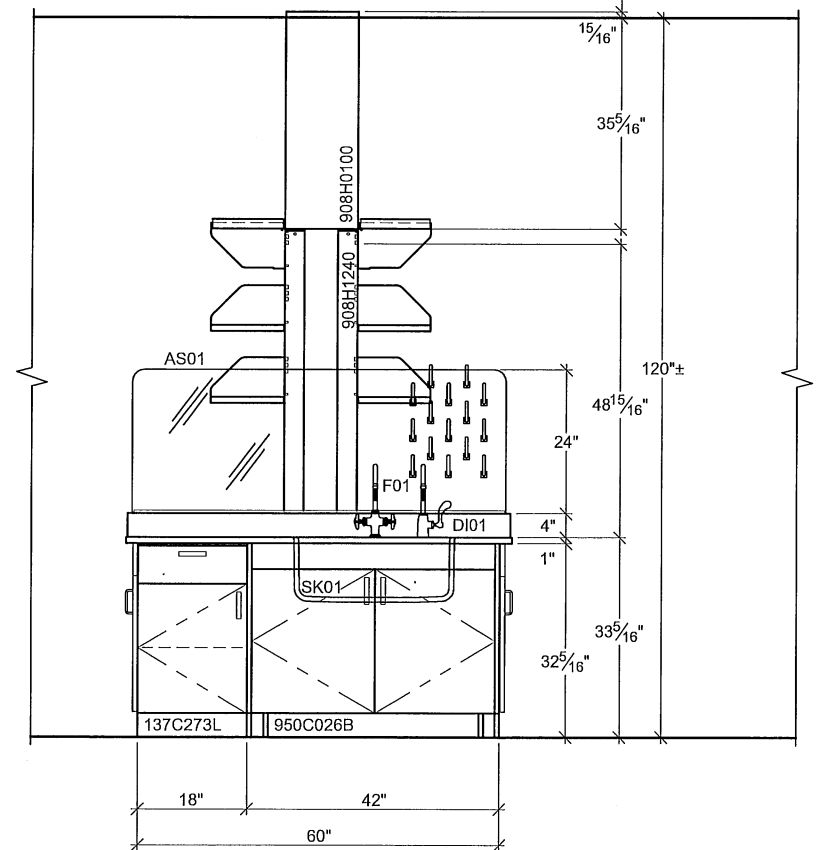

02B ELEVATION & PLAN

CP.01 Quantity: 01
 Room Name: LAB 206
 Room Number: 206
 Section: S1
 Ref. Arch. Elev.:



Isec Corporate Office
 33 Inverness Drive East
 Englewood, CO 80112
 Phone: (303) 790-1444
 Fax: (303) 790-7104
 www.isecinc.com

Northern California Region
 41734 Christy Street
 Fremont, CA 94538
 Phone: (510) 490-1333
 Fax: (510) 656-8764
 Contact: Debbie Silva

Project Name
UC Santa Cruz
 Project Location
Santa Cruz, Ca. 95064

Project Number 115733	Drawing Title Elevation(s) 03A & 03B For Room 206			
Project Phase Number Phase 2 & 3	Drawn By 10/05/07	QC By	Last Revised By	Drawing Set Date ----
			0	Drawing Number CE.04

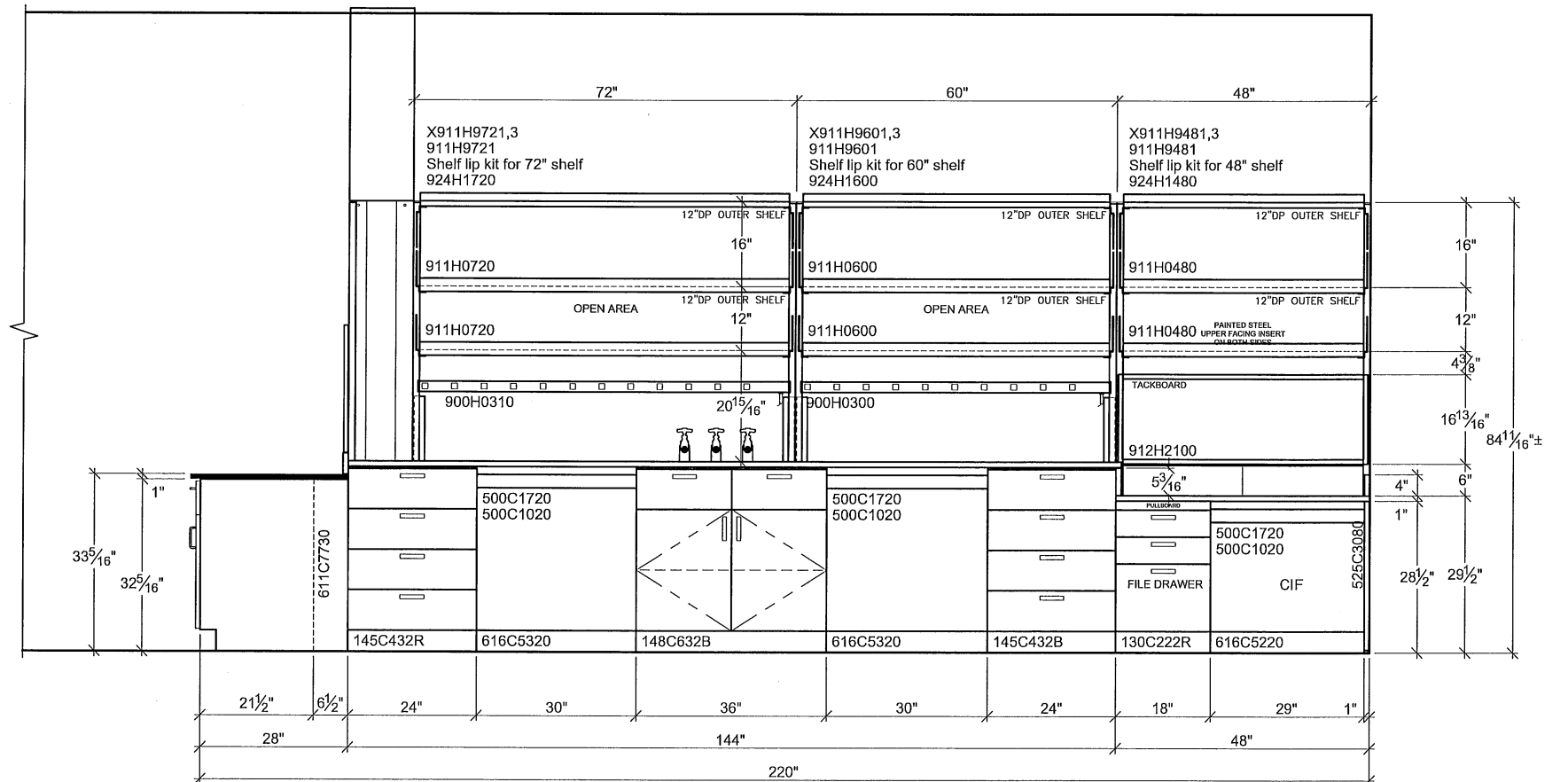

03C ELEVATION & PLAN

CP.02 Quantity: 01
 Room Name: BME LAB#3
 Room Number: 206
 Section: S1
 Ref. Arch. Elev.:



Isec Corporate Office
 33 Inverness Drive East
 Englewood, CO 80112
 Phone: (303) 790-1444
 Fax: (303) 790-7104
 www.isecinc.com

Northern California Region
 41734 Christly Street
 Fremont, CA 94538
 Phone: (510) 490-1333
 Fax: (510) 656-8764
 Contact: Debbie Silva

Project Name
UC Santa Cruz
 Project Location
Santa Cruz, Ca. 95064

Project Number 115733	Drawing Title Elevation(s) 03C For Room 206				
Project Phase Number Phase 2 & 3	Drawn By ----	QC By ----	Last Revised By ----	Drawing Set Date ----	Drawing Number CE.05
	10/05/07				

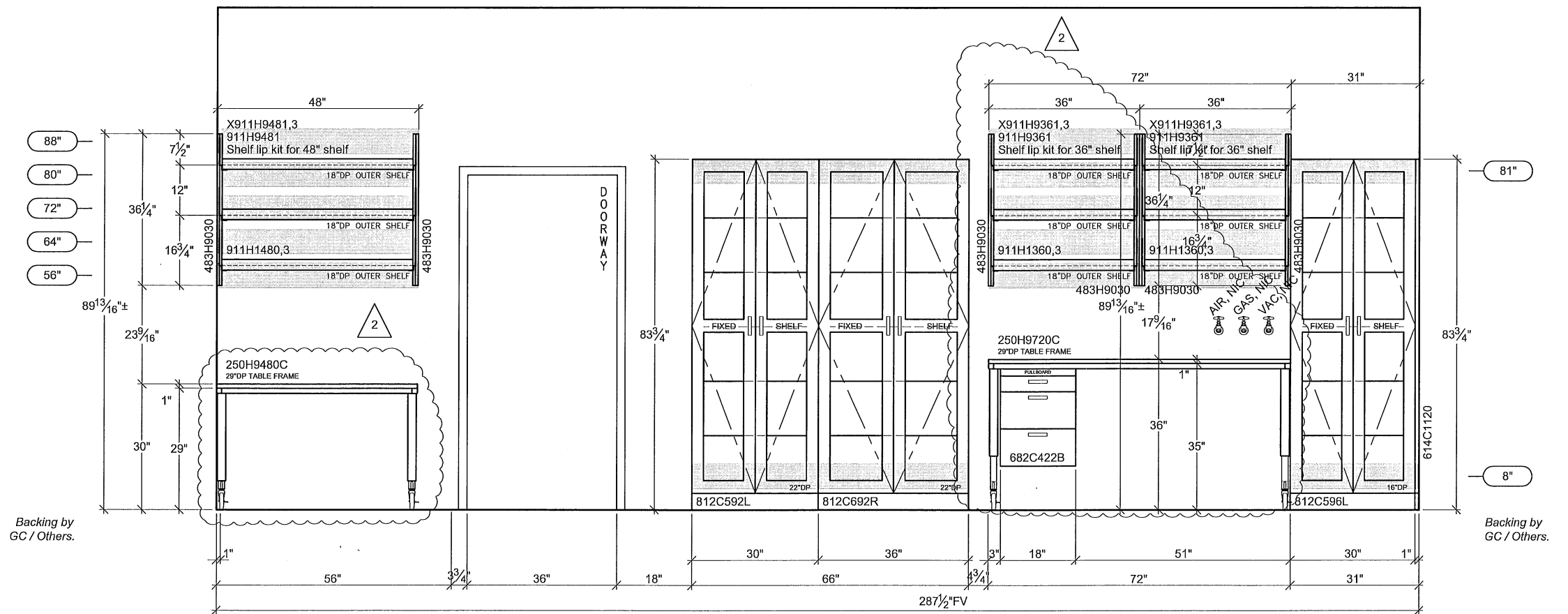
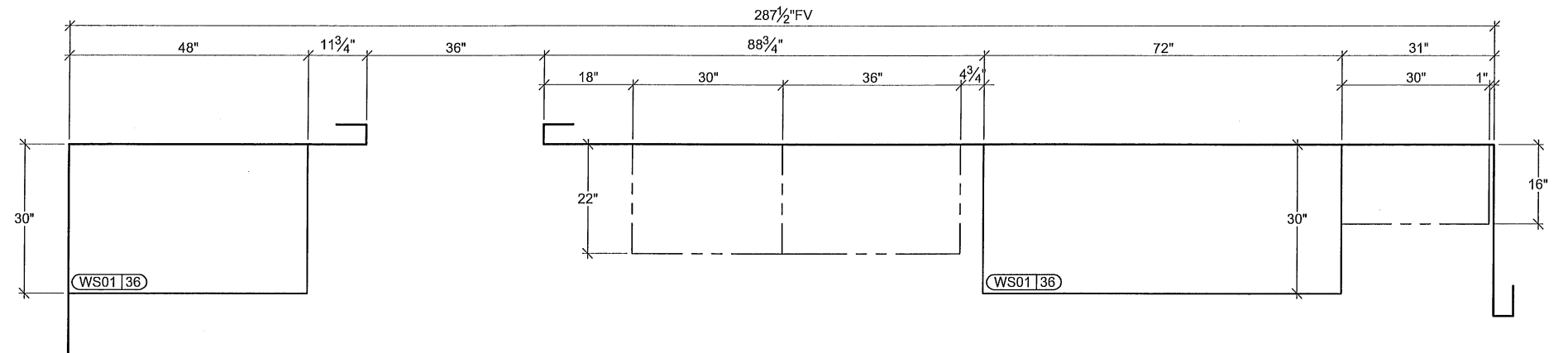

04 ELEVATION & PLAN
 CP.02 Quantity: 01
 Room Name: BME LAB#3
 Room Number: 206
 Section: S1
 Ref. Arch. Elev.:

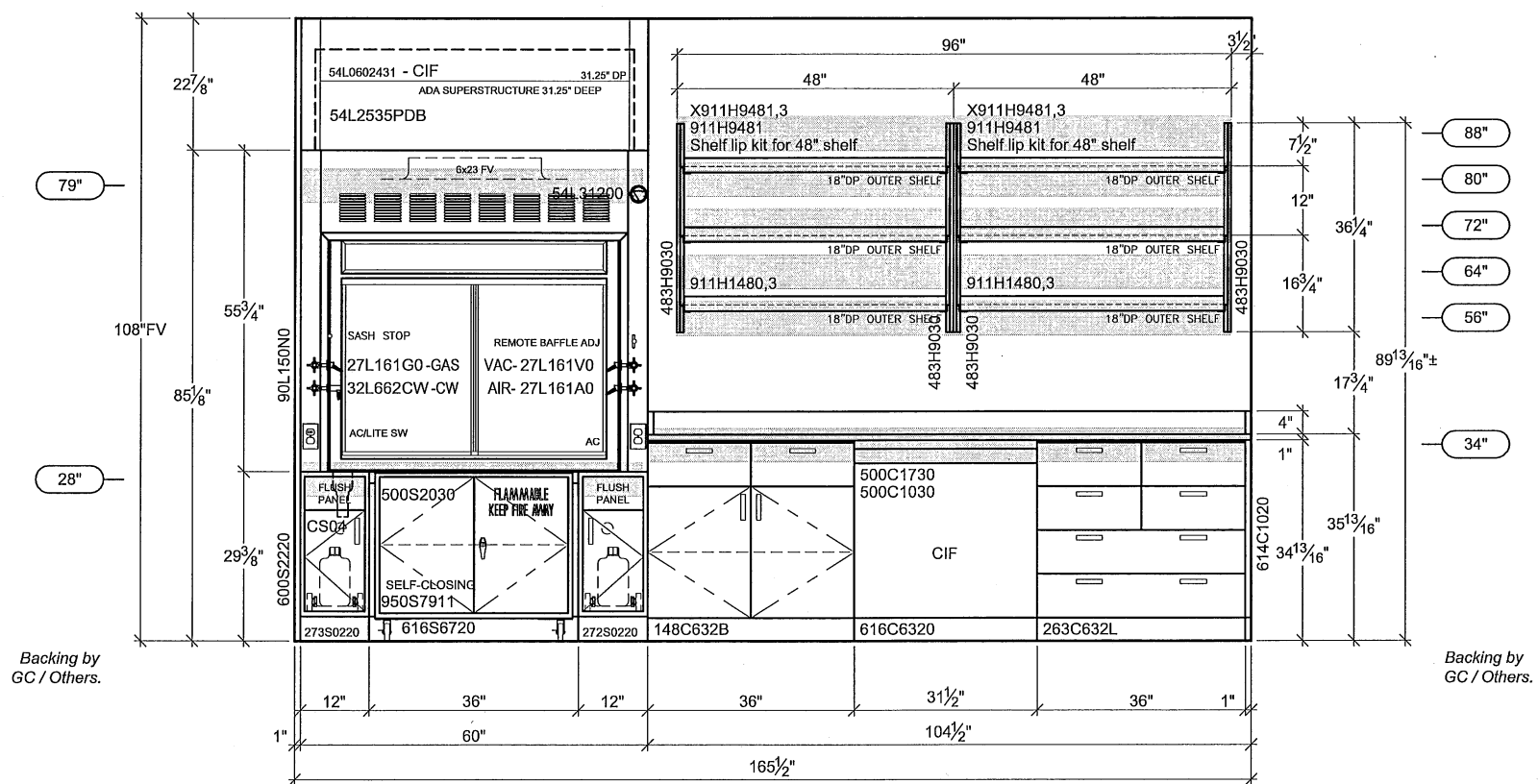
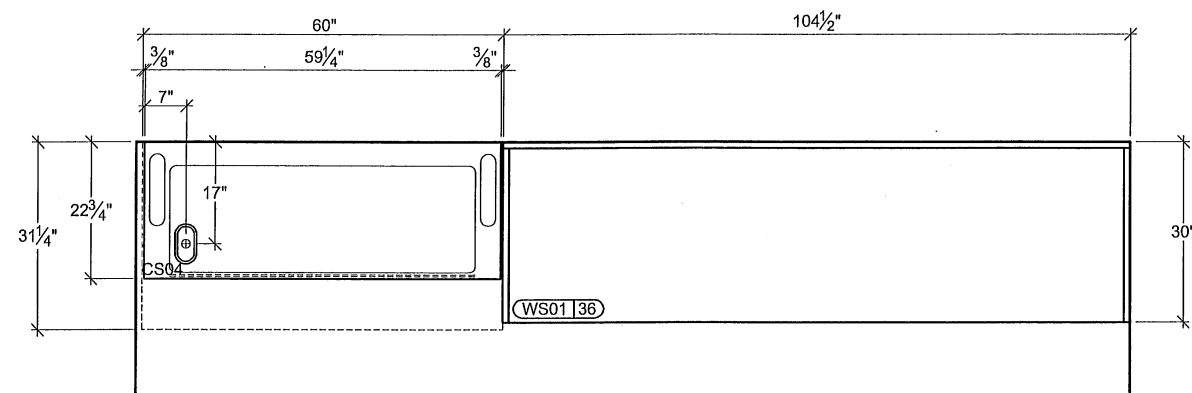

05 ELEVATION & PLAN

CP.02

Quantity: 01
 Room Name: BME LAB#3
 Room Number: 206
 Section: S1
 Ref. Arch. Elev.:



ISEC Corporate Office
 33 Inverness Drive East
 Englewood, CO 80112
 Phone: (303) 790-1444
 Fax: (303) 790-7104
 www.isecinc.com

Northern California Region
 41734 Christy Street
 Fremont, CA 94538
 Phone: (510) 490-1333
 Fax: (510) 656-8764
 Contact: ---

Project Name
UC Santa Cruz

Project Location
Santa Cruz, Ca. 95064

Project Number 115733	Drawing Title Elevation(s) 05 For Room 206				
Project Phase Number Phase 2 & 3	Drawn By ----	QC By ----	Last Revised By ----	Drawing Set Date ----	Drawing Number CE.07
			0		

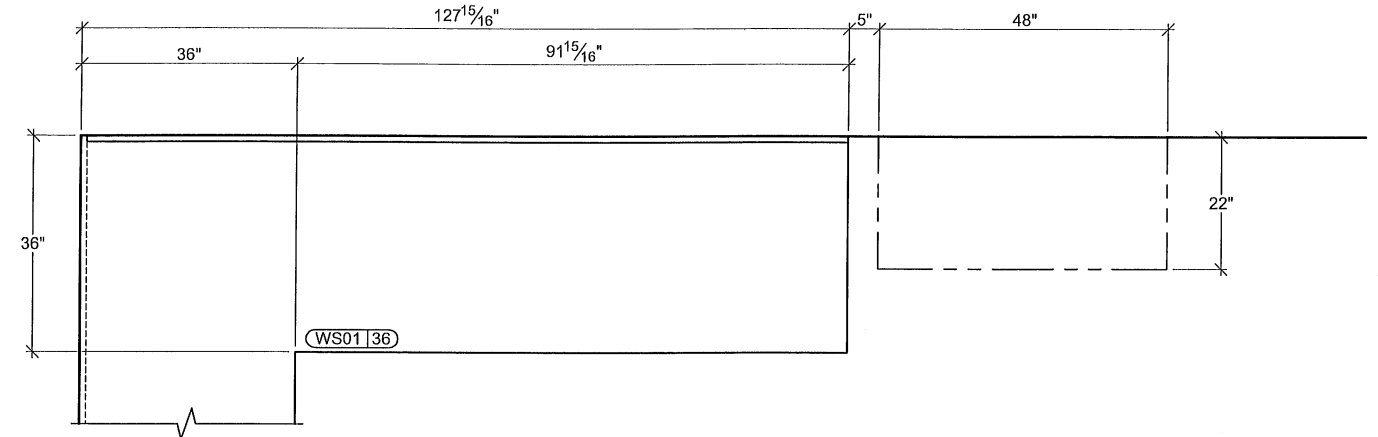
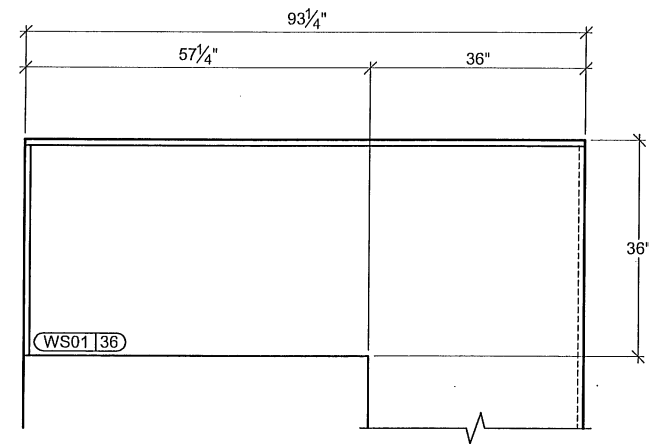

ARCHITECT NOTE:
-CONFIRM THE LOCATION OF THE REFRIGERATOR

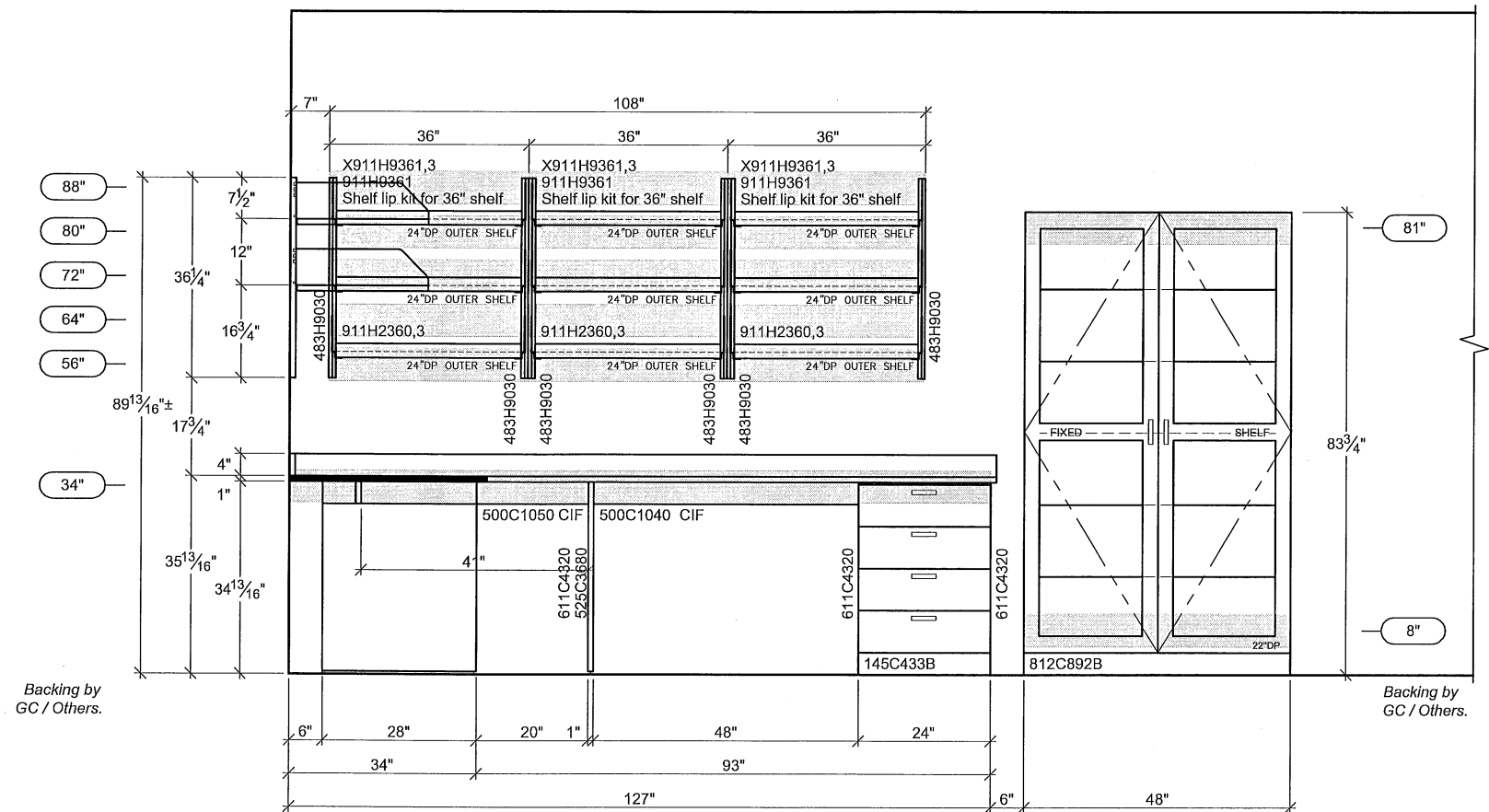
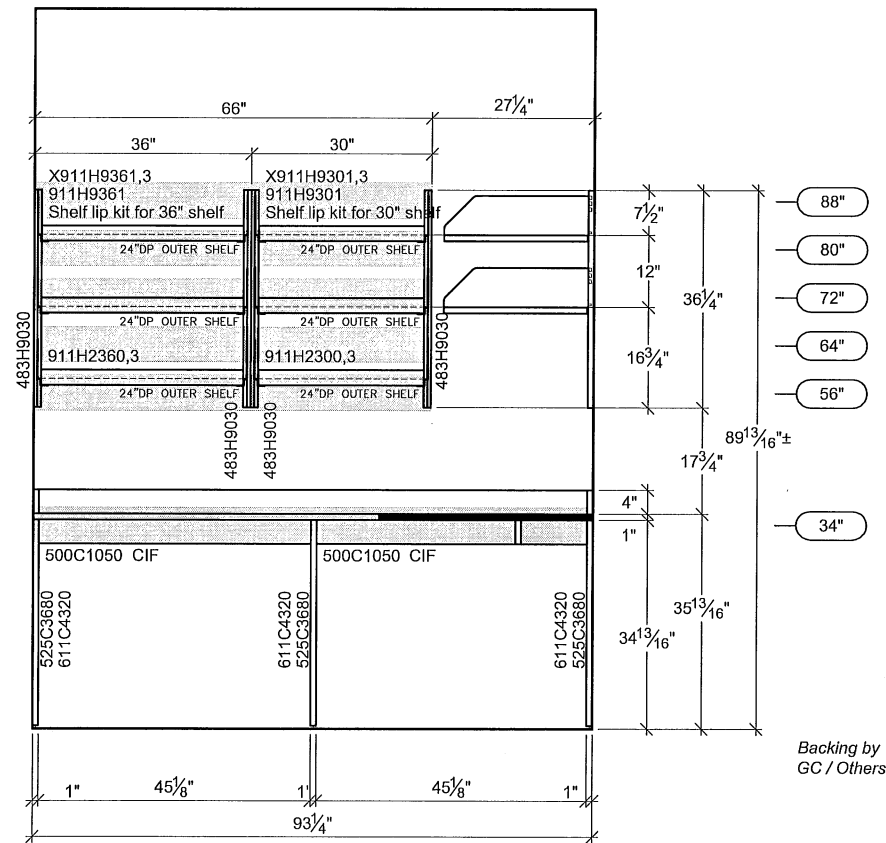

06A ELEVATION & PLAN
CP.02 Quantity: 01
Room Name: TISSUE CULTURE
Room Number: 208
Section: S1
Ref. Arch. Elev.:

06B ELEVATION & PLAN
CP.02 Quantity: 01
Room Name: TISSUE CULTURE
Room Number: 208
Section: S1
Ref. Arch. Elev.:

Project Number 115733	Drawing Title Elevation(s) 06A & 06B For Room 208			
Project Phase Number Phase 2 & 3	Drawn By ----	QC By ----	Last Revised By ----	Drawing Set Date ----
				Drawing Number CE.08

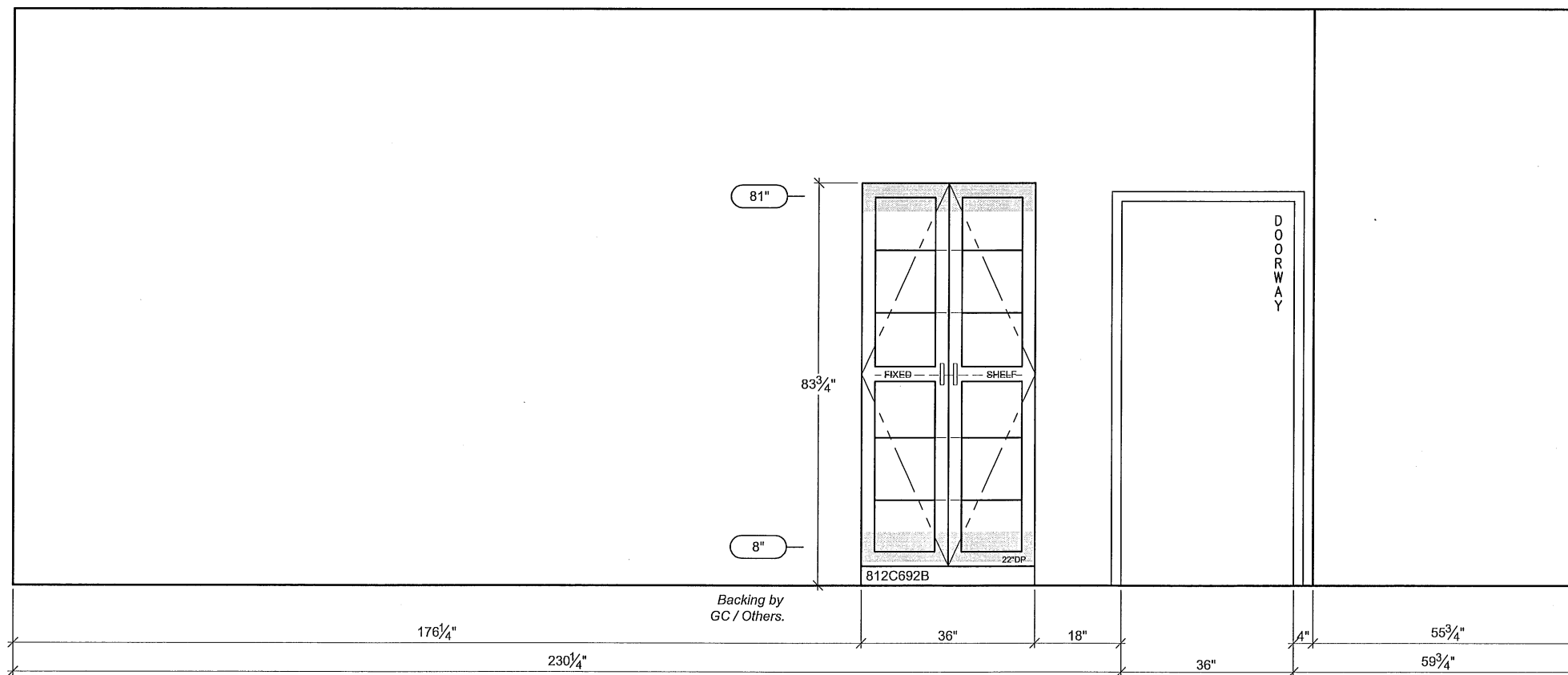
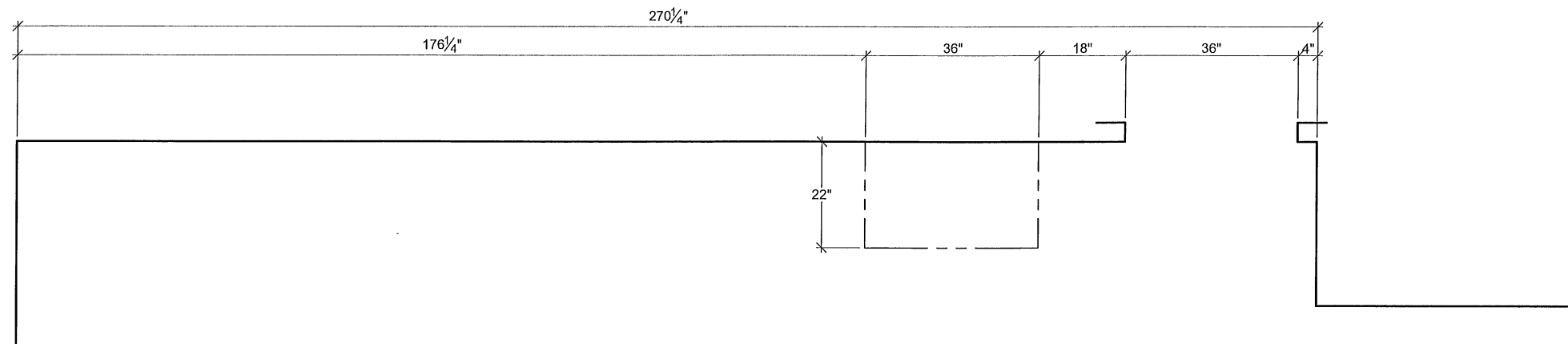

07 ELEVATION & PLAN
 CP.02 Quantity: 01
 Room Name: TISSUE CULTURE
 Room Number: 208
 Section: S1
 Ref. Arch. Elev.:

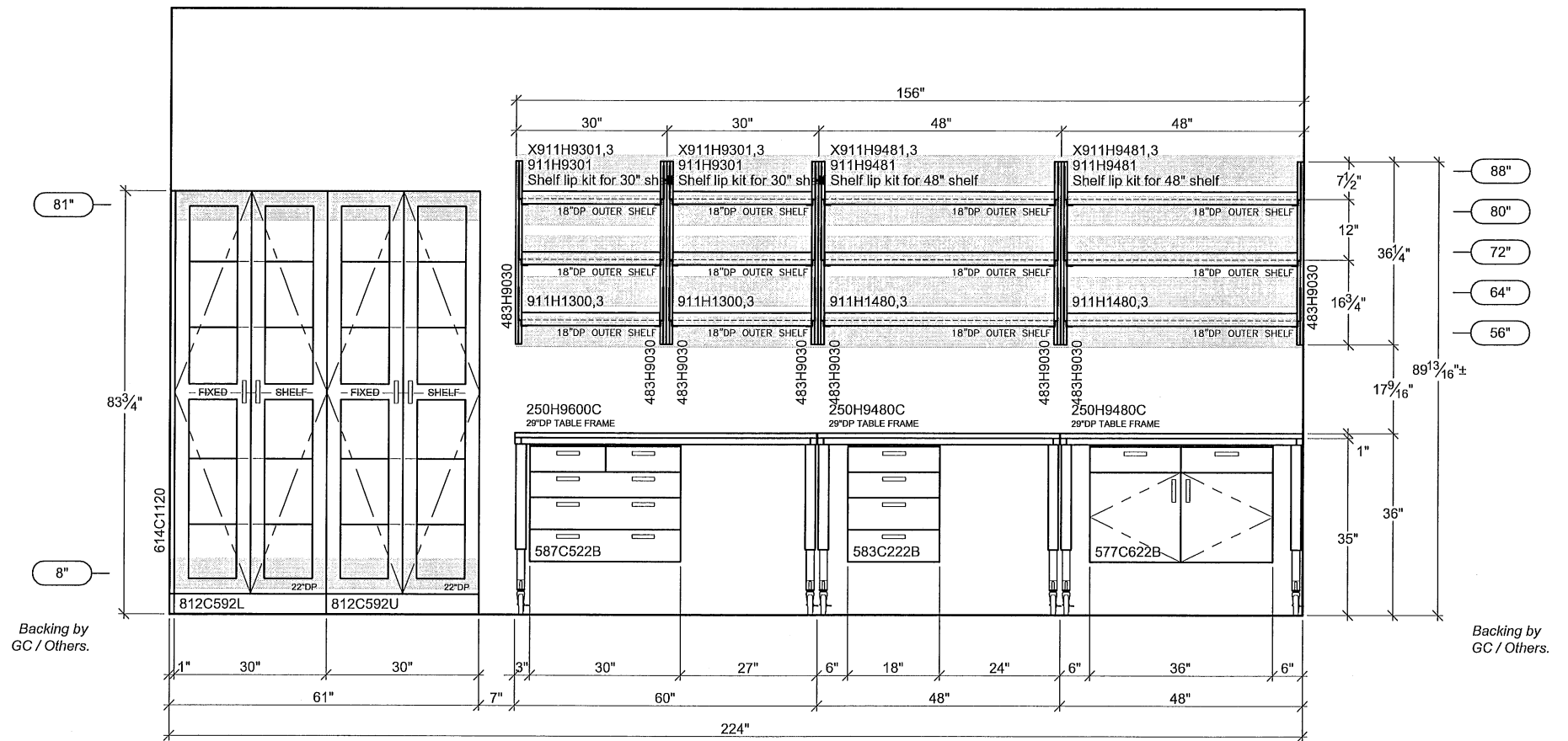
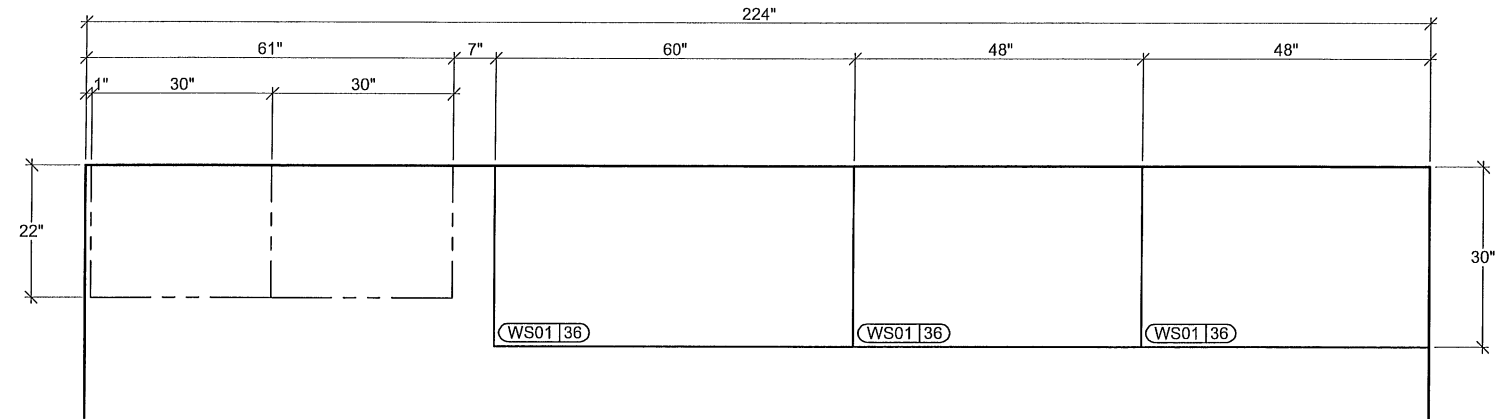

08 ELEVATION & PLAN
 CP.02 Quantity: 01
 Room Name: AUTOMATION
 Room Number: 207
 Section: S1
 Ref. Arch. Elev.:

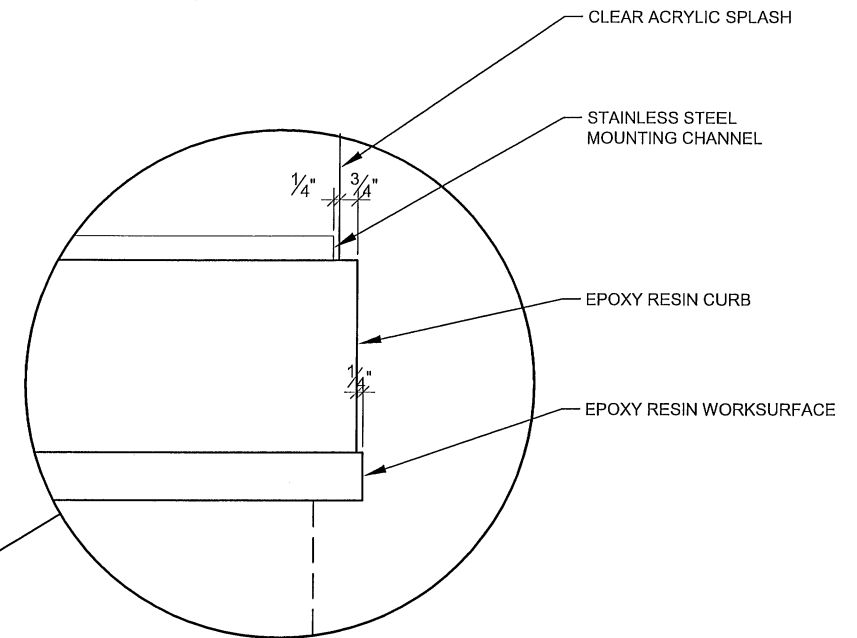
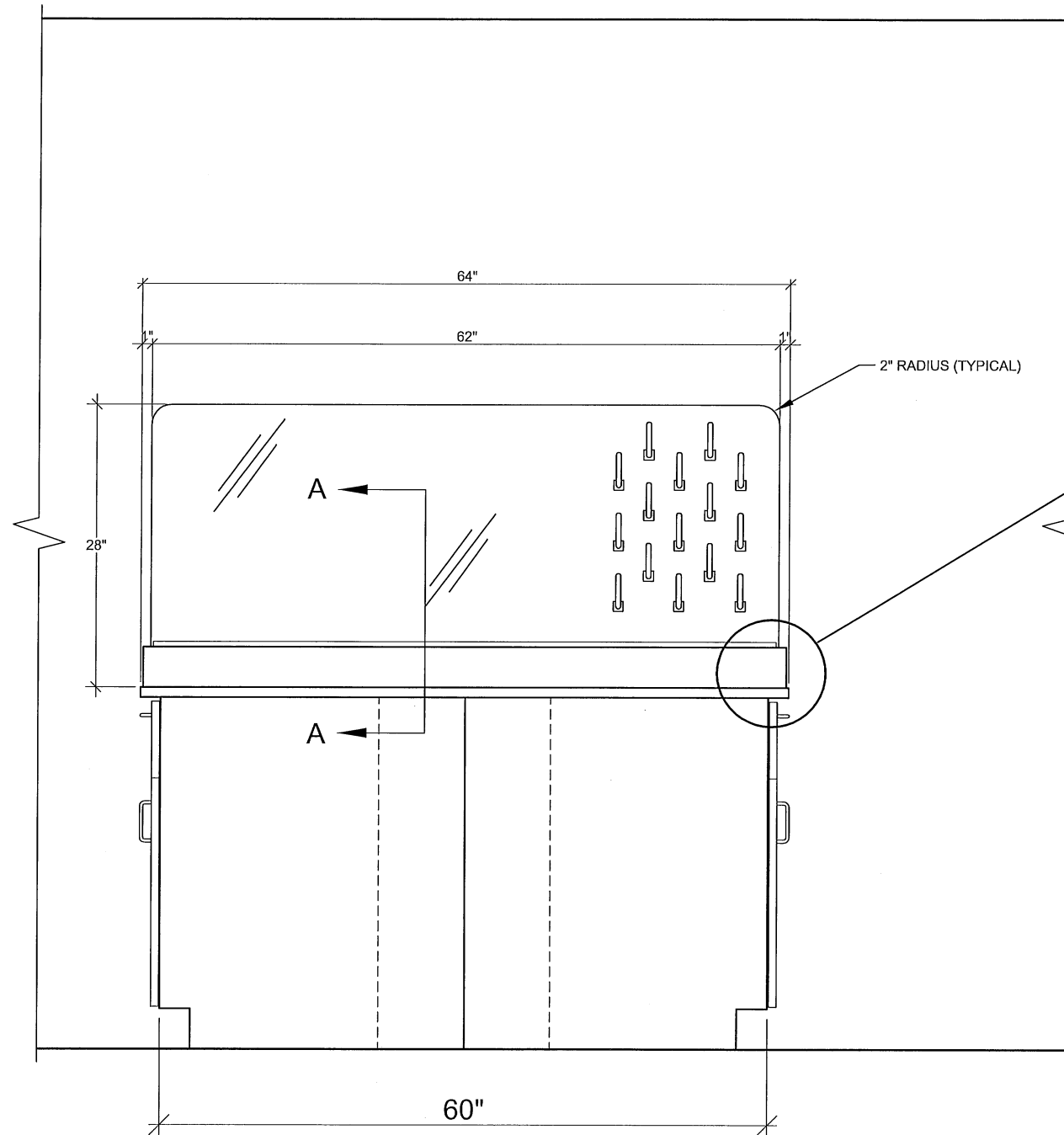

DETAIL OF CURB LOCATION

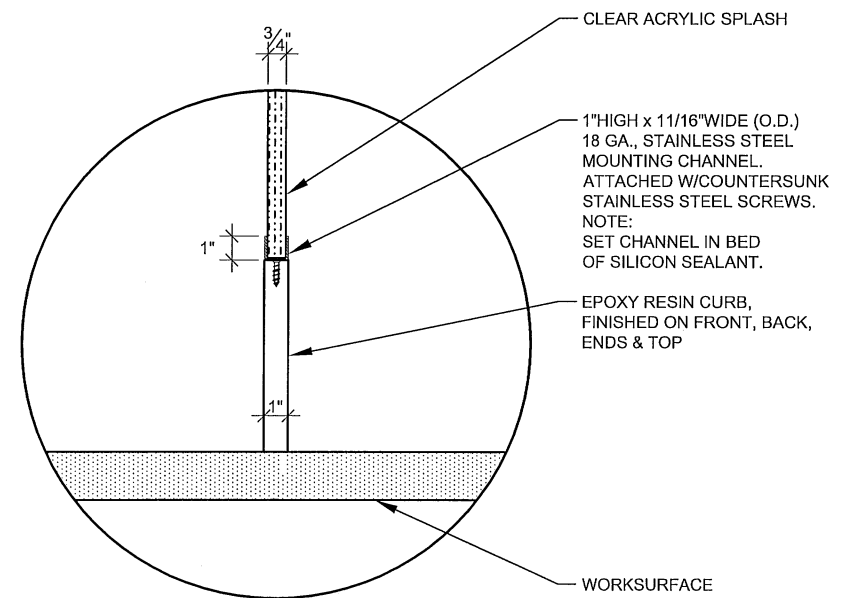

ACRYLIC SPLASH SECTION AA

02 CONSTRUCTION DETAIL FOR:
 CD.02 CLEAR ACRYLIC SPLASH
 AS01



ISEC Corporate Office
 33 Inverness Drive East
 Englewood, CO 80112
 Phone: (303) 790-1444
 Fax: (303) 790-7104
 www.isecinc.com

Northern California Region
 41734 Christy Street
 Fremont, CA 94538
 Phone: (510) 490-1333
 Fax: (510) 656-8764
 Contact: Debbie Silva

Project Name
UC Santa Cruz
 Project Location
Santa Cruz, Ca. 95064

Project Number 115733		Drawing Title Details For Acrylic Splash			
Project Phase Number Phase 2 & 3	Drawn By ----	QC By ----	Last Revised By ----	Drawing Set Date ----	Drawing Number CD.01
			0		